

STREET LIGHTING LUMINAIRE

SL 60 CITY

HIGH EFFICIENCY
NO GLASS

14-75W



up to 188 Lm/W

No glass



LED number	144 LED	144 LED	144 LED	144 LED	144 LED	288 LED	288 LED	288 LED	288 LED
Power**	14W	18W	20W	30W	38W	50W	55W	60W	75W
Luminous flux*	2400 Lm	3400 Lm	3730 Lm	5480 Lm	6690 Lm	8720 Lm	9520 Lm	9970 Lm	12450 Lm
Light efficiency*	182 Lm/W	188 Lm/W	187 Lm/W	182 Lm/W	180 Lm/W	174 Lm/W	172 Lm/W	166 Lm/W	166 Lm/W
LED current	0.020A	0.024A	0.024A	0.035A	0.040A	0.056A	0.060A	0.066A	0.040A

*Data is for 4000K and 5000K. For 3000K contact manufacturer. **Power tolerance +/-5%

TRIDONIC Philips Xitanium



WWW.BSM-BG.COM

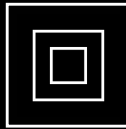

STREET LIGHTING LUMINAIRE

SL 60 CITY

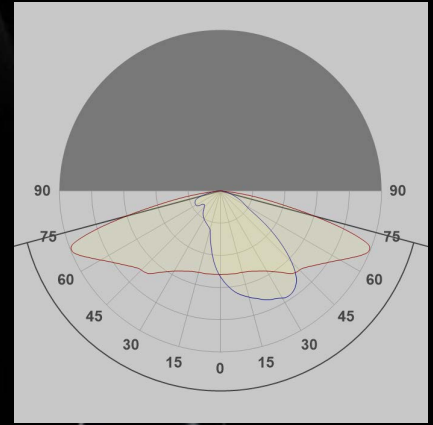
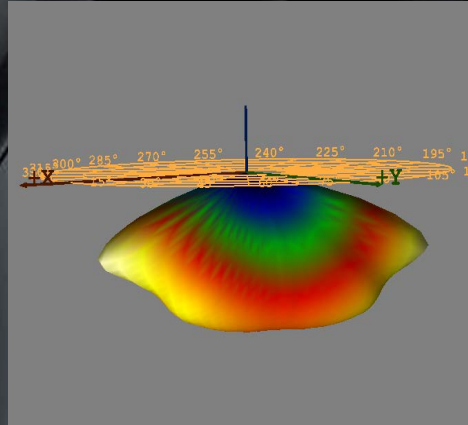
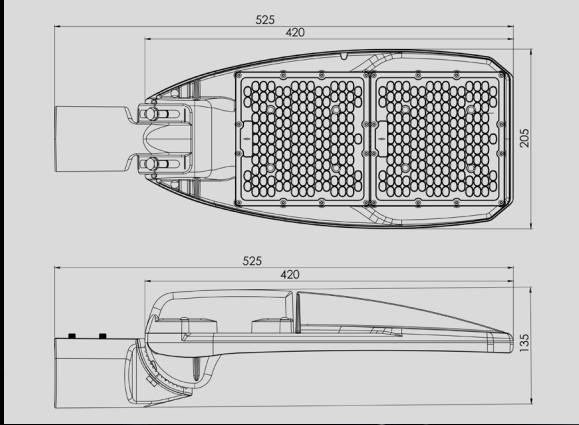

LED brand	LUMILEDS LUXEON 3030 2D SAMSUNG 3535
Lenses / Optics	2x72 LED optics
Power supply voltage	AC 220-240V (+/-10%), 50/60Hz (on request AC 100-277V voltage range)
LED driver	TRIDONIC, PHILIPS, TCI, MEANWELL; On request: 1-10V, DALI, Self-dimming; NTC, CLO, etc.
Operation temperature	-25°C + 50°C (-30°C or -40°C on request)
Isulation class	Class I or Class II
Beam Angle	street type 145°, 150°
Power factor	≥0.90
Operation Lifetime	≥ 60,000 h at L80B10 (100,000 h on request)
Surge protection	10kV
CR Index	CRI Ra≥70 (CRI Ra≥80 on request)
Colour temperature	4000K; 5000K (3000K on request) +/- 300K (Luminocity parameters may vary on request)

(The flux and efficiency may vary +/- 10%, depending on the LEDs)

Specifications are subject to change without notice, for latest datasheet refer to web-site

Body colour	RAL7035 standard - custom colour possible on request RAL9006, RAL7024
Body / Screen	Aluminium die casting (powder coated)
IP / IK grade	IP66 / IK09 (IK10)
Weight	4 kg
Dimensions	420x205x135mm
Mounting / Tilt angle	diam. 60mm top mount +20° - 0° / Boom +25° - 25°
Warranty	5 years (7 and 10 years on request)
Main standards references	CE; EN 55015; EN 61000; EN 61547; EN 62031 EN 60598; EN 62262; EN 13201; EN 62471

TRIDONIC Philips Xitanium



WWW.BSM-BG.COM